

# SERVICE MANUAL

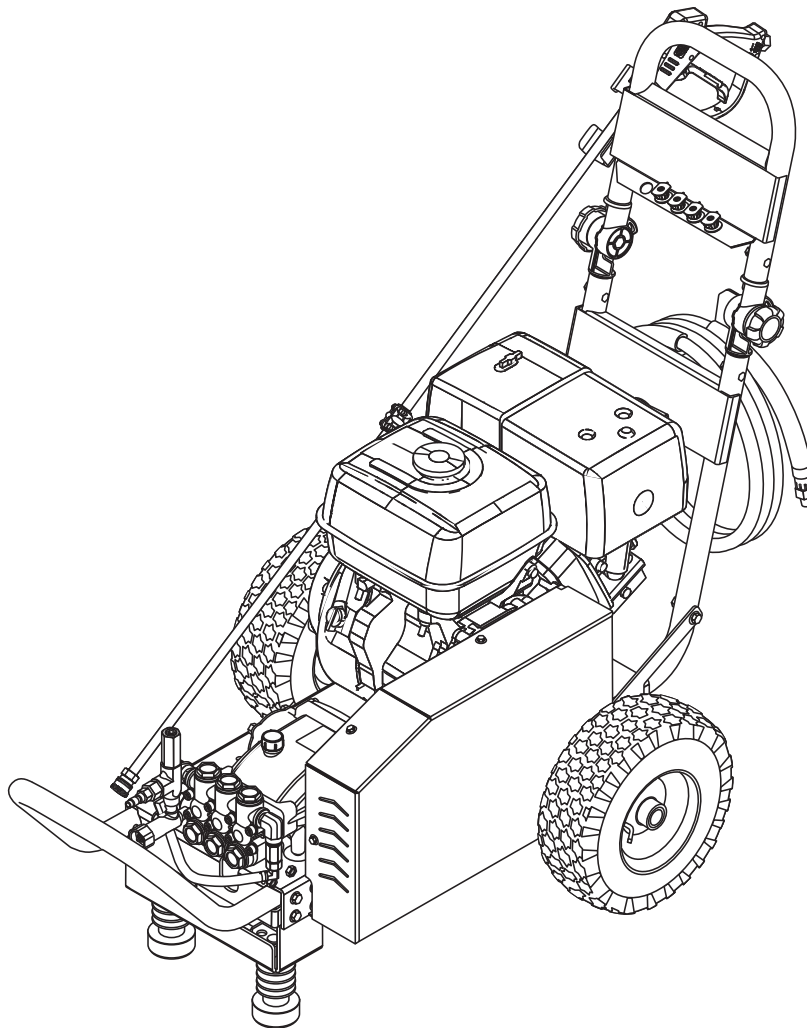

**MODEL #**

**ORDER #**

**HD 2.5/27 PB AL**

**1.107-132.0**

**HD 3.7/35 PB AL**

**1.107-133.0**

**PGA3-27324**

**1.107-127.0**

**PGA4-35324**

**1.107-128.0**

**BXA-252739**

**1.107-120.0**

**BXA-373539**

**1.107-121.0**

**BGA-252737**

**1.106-057.0**

**BGA-373537**

**1.106-058.0**

# CONTENTS

---

Exploded View .....	4
Exploded View Parts List .....	5-7
M4035R.3 Pump Assembly Exploded and View .....	8
M4035R.3 Series Pump Exploded and Parts List.....	9-10
D3030R.1 Pump Assembly Exploded and View .....	11
D3030R.1 Series Pump Exploded and Parts List.....	12-13
Unloader Exploded and Parts List .....	14
Troubleshooting .....	15-17
Preventive Maintenance .....	17
Oil Change Record .....	18

## TROUBLESHOOTING

PROBLEM	POSSIBLE CAUSE	SOLUTION
<b>LOW OPERATING PRESSURE</b>	Faulty pressure gauge	Install new gauge.
	Insufficient water supply	Use larger supply hose; clean filter at water inlet.
	Old, worn or incorrect spray nozzle	Match nozzle number to machine and/or replace with new nozzle.
	Belt slippage	Tighten or replace; use correct belt.
	Plumbing or hose leak	Check plumbing system for leaks. Re-tape leaks with teflon tape.
	Faulty or mis-adjusted unloader valve	Adjust unloader for proper pressure. Install repair kit when needed.
	Worn packing in pump	Install new packing kit.
	Fouled or dirty inlet or discharge valves in pump	Clean inlet and discharge valves.
	Worn inlet or discharge valves	Replace with valve kit.
	Obstruction in spray nozzle	Remove obstruction.
	Leaking pressure control valve	Rebuild or replace as needed.
	Slow engine RPM	Set engine speed at proper specifications.
	Pump sucking air	Check water supply and possibility of air seepage.
	Valves sticking	Check and clean or replace if necessary.
Unloader valve seat faulty	Check and replace if necessary.	
<b>FLUCTUATING PRESSURE</b>	Worn or dirty pump valves	Call local distributor.
	Nozzle is obstructed	Blow out or remove debris with fine needle.
	Pump sucking air, inlet hose leaking	Check that all hoses and fittings are airtight. Turn off machine and trigger spray gun until a steady flow of water emerges through the nozzle.
	Insufficient water supply	Turn water on full force. Check garden hose for kinks, leaks or blockage.
<b>PRESSURE LOW AFTER PERIOD OF NORMAL USE</b>	Nozzle worn	Replace nozzle.
	Unloader valve worn	Replace unloader valve.
<b>ENGINE WILL NOT START OR STOPS WHILE OPERATING</b>	Low oil shutdown	Fill engine with oil.
	Out of gas	Fill fuel tank.
	Water in gasoline	Drain gas tank; fill with clean fuel.
<b>ENGINE IS OVERLOADED</b>	Nozzle partially blocked	Clean nozzle.
	Excessive pressure from high engine RPM	Adjust engine throttle to lower RPM.

## TROUBLESHOOTING

<b>PROBLEM</b>	<b>POSSIBLE CAUSE</b>	<b>SOLUTION</b>
<b>WATER OR OIL LEAKING FROM BOTTOM OF PUMP</b>	A small amount of leaking is normal	If excessive leaking occurs, call local distributor.
<b>PRESENCE OF WATER IN PUMP OIL</b>	Water sprayed at machine	Change oil. Direct spray away from machine.
	High humidity in air	Check and change oil twice as often.
	Piston packing worn. Oil seal worn.	Call local distributor.
<b>ENGINE OPERATES FOR 15 MINUTES THEN STOPS</b>	Not enough gas or engine oil	Fill tank with gas. Check oil level.
	Vapor lock developed by heat of day	Keep gas tank full to avoid vapor locking.
	Obstruction in fuel filter	Clean or replace fuel filter.
<b>ENGINE LACKS POWER</b>	Dirty air filter	Replace air filter.
<b>ENGINE FALTERS</b>	Choke is opened too soon	Move choke to halfway position until engine runs smoothly.
<b>WATER DRIPPING FROM UNDER PUMP</b>	Piston packing worn	Call local distributor.
	O-Ring plunger retainer worn	Call local distributor.
	Cracked piston	Call local distributor.
<b>OIL DRIPPING FROM UNDER PUMP</b>	Oil seal worn or damaged	Call local distributor.
<b>WATER LEAKING FROM PUMP PROTECTOR</b>	Spray gun closed with machine running 5 minutes or longer	Open spray gun or turn off machine.
	Excess water supply pressure	Place a pressure regulator at end of 50' garden hose.
<b>NO DETERGENT</b>	Detergent suction tube not properly connected to machine	Check connection.
	Detergent is too thick	Dilute detergent. For best results, use manufacturers detergent.
	Detergent filter valve is at lowest setting	Set detergent filter valve to a higher setting.
	Filter on detergent suction tube is clogged	Run warm water through filter to remove debris.
	Damaged or clogged detergent suction tube	Remove obstruction or replace detergent suction tube.
	A high pressure nozzle is attached.	Replace with black detergent nozzle.
	Discharge nozzle is obstructed	Blow out or remove debris with fine needle.
<b>GARDEN HOSE CONNECTION LEAKS</b>	Loose fittings	Tighten fittings.
	Missing/worn rubber washer	Insert new washer.

## TROUBLESHOOTING

PROBLEM	POSSIBLE CAUSE	SOLUTION
<b>SPRAY WAND LEAKS</b>	Spray wand not properly attached	Slide the spray wand into the gun. Turn the wand collar clockwise onto the spray gun threads until tight.
	Broken o-ring	Call local distributor and order an o-ring.
<b>PUMP IS NOISY</b>	Pump is sucking air	Check that hoses and fittings are air tight. Turn off machine and purge pump by squeezing trigger gun until a steady flow of water emerges through nozzle.

## PREVENTATIVE MAINTENANCE

This pressure washer was produced with the best available materials and quality craftsmanship. However, you as the owner have certain responsibilities for the correct care of the equipment. Attention to regular preventative maintenance procedures will assist in preserving the performance of your equipment. Contact your dealer for maintenance. Regular preventative maintenance will add many hours to the life of your pressure washer. Perform maintenance more often under severe conditions. Check pump oil and engine oil level before first use of your new pressure washer.

MAINTENANCE SCHEDULE		
Engine Oil	Inspect	Daily
	Change	First month or 20 hours. Every 100 hours or every 6 months after first month
	Filter	Every 50 hours
Air Cleaner/Filter	Inspect	Daily
	Clean	Every 3 months or 50 hours
Engine Fuel Filter		500 hours or 6 months
Spark Plug Maintenance	Inspect	Every 6 months or 100 hours
	Change	Every year or 300 hours
Clean Fuel Tank(s)		Annually
Pump Oil	Inspect	Oil level daily
	Change	After first 50 hours, then every 500 hours or annually (or 3 months)
Replace High Pressure Nozzle		Every 6 months
Replace Quick Connects		Annually
Clean Water Screen/Filter		Weekly
Replace HP Hose		Annually (if there are any signs of wear)
Belts*	Tighten	Every 6 months
	Inspect/Replace	Every 6 months

**\*Note:** When servicing belts, don't exceed 14 lb-ft on pump mounting screws. Failure to do so will cause pump thread damage.

## OIL CHANGE RECORD

Check pump oil and engine oil level before first use of your new pressure washer.

Date Oil Changed Month/Day/Year	Estimated Operating Hours Since Last Oil Change

Date Oil Changed Month/Day/Year	Estimated Operating Hours Since Last Oil Change

# EXPLODED VIEW

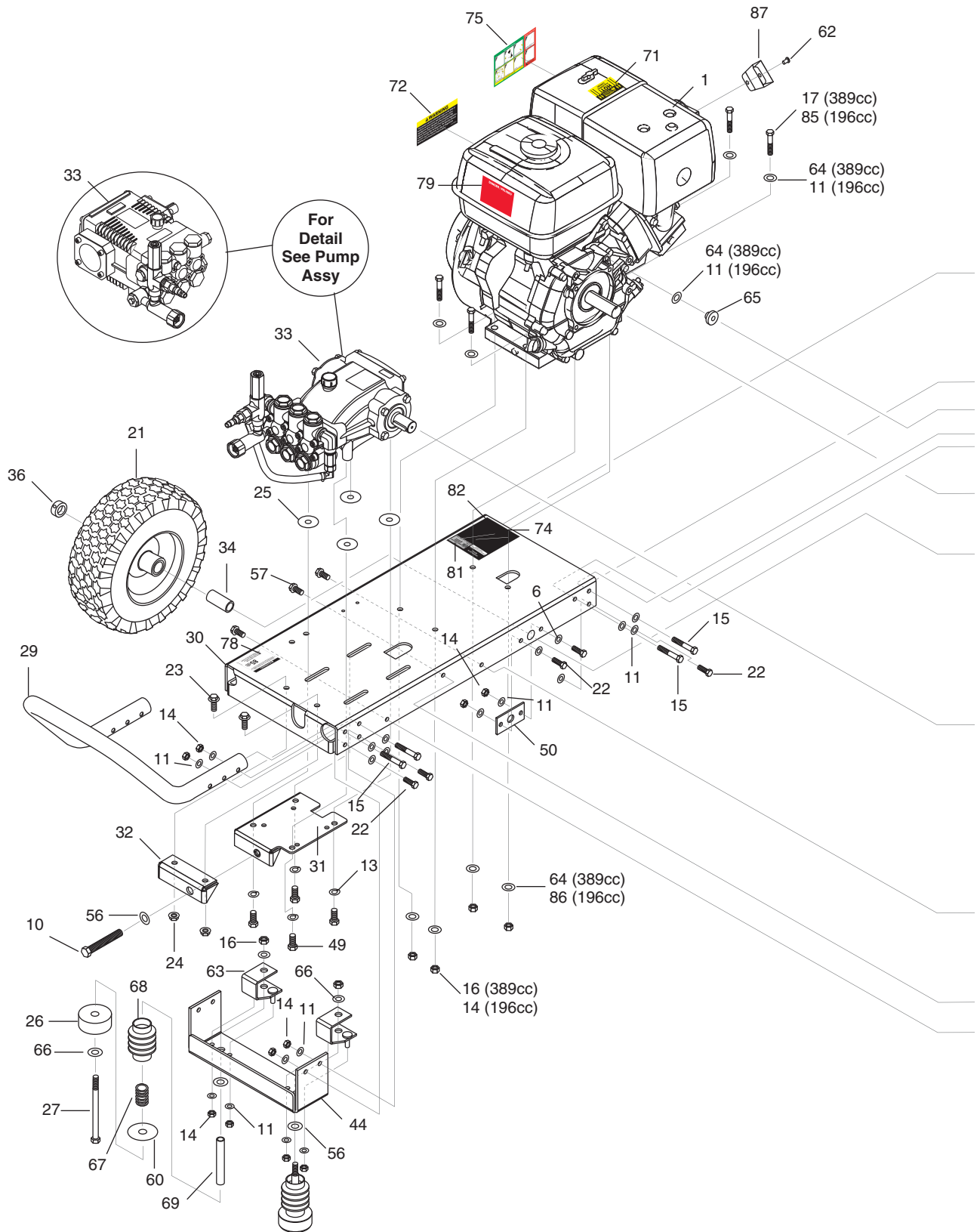

# EXPLODED VIEW

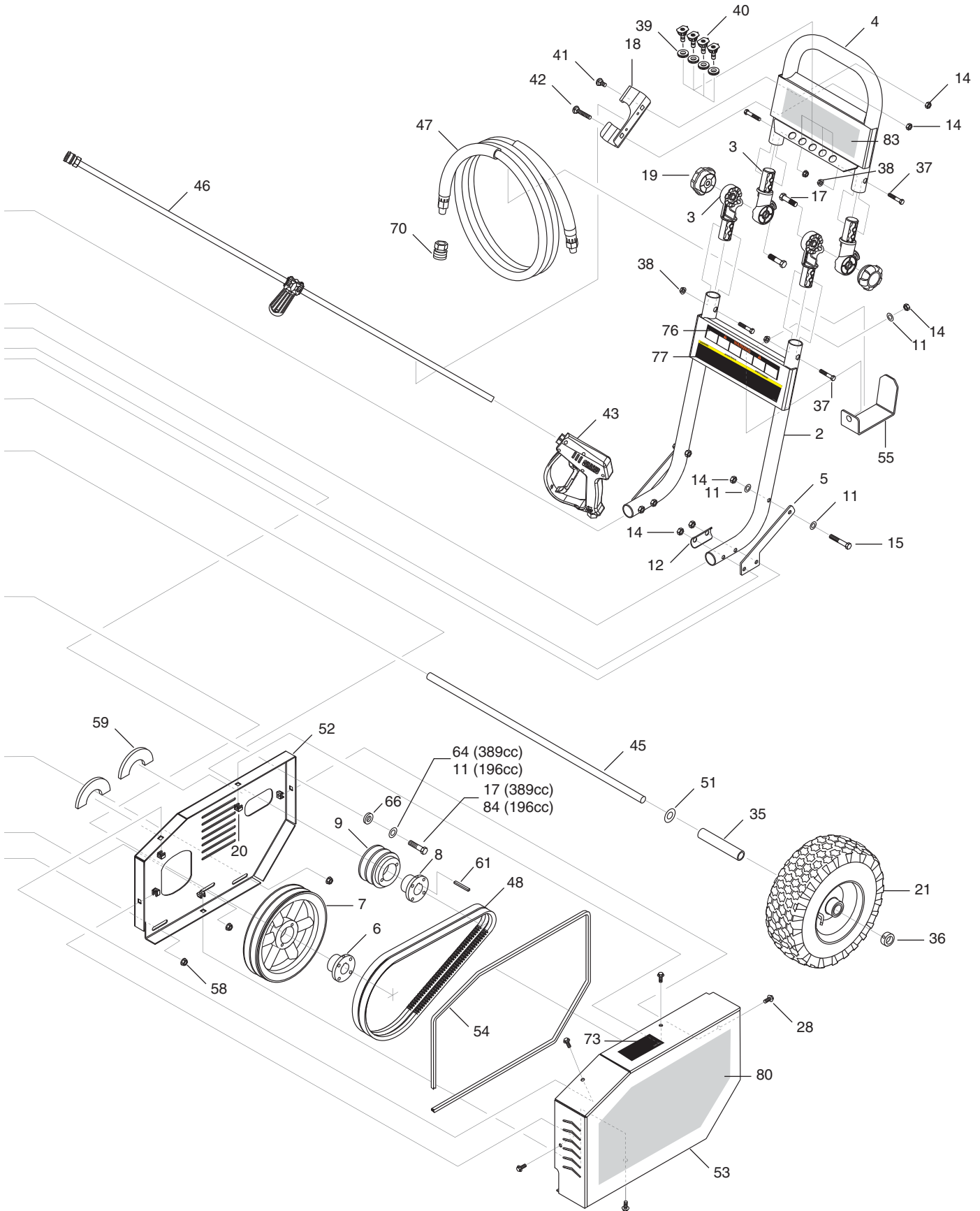



## EXPLODED VIEW PARTS LIST (CONT)

ITEM	PART NO.	DESCRIPTION	QTY	ITEM	PART NO.	DESCRIPTION	QTY
1	8.750-580.0	Engine, Honda, GX390UT2QA2 (389 cc)	1	30	8.919-349.0	Al Base Long (389 cc)	1
	9.802-317.0	Engine, Honda, GX200UTQX2 (196 cc)	1		8.919-401.0	Al Base Short (196 cc)	1
2	8.917-978.0	Handle Support Assy Al Direct Drive	1	31	8.919-352.0	Under-Frame Slider	1
3	9.135-007.0	Rotary Tube-Joint	4	32	8.919-354.0	Slider Stiffener Long	1
4	8.917-976.0	Handle Assy Al Direct Drive	1		33	Pump Assy 2700 PSI (See M4035R Specs Pages)	1
5	8.750-303.0	Handle Stiffener Al	2		Pump Assy 3500 PSI (See D3030R Specs Pages)	1	
6	9.802-402.0	Bushing, H X 24MM	1	34	8.919-356.0	Axle Spacer RH 2.0" (389 cc)	1
7	8.715-593.0	Pulley, 2BK 90 H (389 cc)	1		8.918-079.0	Axle Spacer Silver (196 cc)	1
8	9.802-380.0	Pulley, BK 80 H (196 cc)	1	35	8.919-358.0	Axle Spacer Left 5.00"	1
	9.802-399.0	Bushing, H X 1 (389 cc)	1	36	9.802-782.0	Collar, 5/8" Bore Shaft	2
9	9.803-897.0	Bushing, H X 3/4 (196 cc)	1	37	9.196-307.0	1/4-20 x 1-1/2 GR 2 Hex Bolt Zinc	4
	8.715-576.0	Pulley, 2BK 32 H (389 cc)	1	38	9.197-010.0	1/4-20 Nylon Insert Lock Nut	4
9.802-379.0	Pulley, BK 36 H (196 cc)	1	39		9.177-204.0	Sleeve rubber	4
10	9.802-740.0	Bolt, 1/2 X 3-1/2", NC HH(615595)	1	40	Quick Connect Nozzle Kit (389 cc)	1	
11	8.718-980.0	Washer, 5/16" (389 cc) (196 cc)	41 47		8.712-345.0	▲ Nozzle, SAQCMEG 0004, RED	
12	9.803-114.0	Retainer Bracket, Handle, Black	2	8.712-346.0	▲ Nozzle, SAQCMEG 1504, YELLOW		
13	9.802-816.0	Washer, 7/16", Lock Split Ring (389 cc)	4	8.712-347.0	▲ Nozzle, SAQCMEG 2504, GREEN		
	9.802-813.0	Washer, 5/16", Lock Split Ring (196 cc)	4	8.712-348.0	▲ Nozzle, SAQCMEG 4004, WHITE		
14	9.802-776.0	Nylon Insert Nut 5/16" (389 cc) (196 cc)	27 31		Quick Connect Nozzle Kit (196 cc)	1	
15	9.802-716.0	Bolt, 5/16" X 2"	10	8.712-331.0	▲ Nozzle, SAQCMEG 0003, Red		
16	9.197-003.0	3/8-16 Nylon Insert (389 cc)	6	8.712-333.0	▲ Nozzle, SAQCMEG 1503, Yellow		
		(196 cc)	2	8.712-334.0	▲ Nozzle, SAQCMEG 2503, Green		
17	9.196-041.0	Hex Head Bolt 3/8-16 X 1-3/4 (389 cc)	7	8.712-335.0	▲ Nozzle, SAQCMEG 4003, White		
		(196 cc)	2	41	8.718-625.0	Bolt, 5/16"-18X3/4", NC Crrge	1
18	8.918-437.0	Holder Wand Left Silver	1	42	9.802-712.0	Bolt, 5/16"-18 X 1-3/4", NC Carriage	1
19	9.136-502.0	Knob	2	43	8.750-247.0	Trigger Gun Model M407	1
20	9.802-793.0	Nut, Cage, 1/4" X 16 GA	5	44	8.919-348.0	Al Foot Belt Drive (389 cc)	1
		8.711-907.0	Wheel & Tire, 6.5" Steel Rim, 12.5 Tire (389 cc)		2	8.919-421.0	Al Foot Belt Drive Short(196 cc)
21	9.802-270.0	Wheel & Tire Assy, 10" Steel Rim (196 cc)	2	45	8.908-395.0	Axle, 5/8" x 26.80" (389 cc)	1
		9.802-710.0	Screw 5/16" x 1" NC		10	8.919-422.0	Axle Short Base Al 24" (196 cc)
22	9.802-710.0	Screw 5/16" x 1" NC	10	46	8.783-040.0	Wand 44" Zinc Plated, Handle & Coupler (389 cc)	1
23	9.802-767.0	Screw, 3/8" X 3/4"	2		8.783-039.0	Wand 30" Zinc Plated, Handle & Coupler (196 cc)	1
24	9.802-781.0	Nut, 3/8" NC, Whiz Loc Flange	2				
25	9.802-811.0	Washer, 3/8" X 1-1/2" (389 cc)	4				
26	9.802-066.0	Pad Soft Rubber	2				
27	8.718-684.0	Bolt, 3/8" X 5"	2				
28	9.802-754.0	Screw, 1/4" x 1/2" NC	5				
29	8.919-712.0	Aluminium Bumper	1				

## EXPLODED VIEW PARTS LIST (CONT)

ITEM	PART NO.	DESCRIPTION	QTY	ITEM	PART NO.	DESCRIPTION	QTY
47	8.916-740.0	Hose, 3/8" x 50', 1 Wire Tuff-Skin (BGA Models)	1	76	8.783-036.0	Label, Warning Pictogram	1
	8.739-011.0	Hose, 3/8" x 50', 1 Wire Tuff-Skin (BXA Models)	1	77	8.750-809.0	Label Operation Warn Trilingual Small	1
	8.739-021.0	Hose, 3/8" x 50', 1 Wire Tuff-Skin (HD Models)	1	78	8.783-038.0	Label, Universal DB Rating, Ear Protection	1
	8.739-026.0	Hose, 3/8" x 50', 1 Wire Tuff-Skin (PGA Models)	1	79	9.800-008.0	Label, Danger Cool Engine	1
48	9.802-417.0	Belt, BX38 (389 cc)	2	80	8.751-861.0	Label, Long (HD Models) (389 cc)	1
	8.715-695.0	Belt, BX34 (196 cc)	1		8.751-862.0	Label, Short (HD Models) (196 cc)	1
49	8.751-212.0	Bolt M10 X 25MM (389 cc)	4		8.750-465.0	Label, Guard (PGA Models)	1
	9.802-742.0	Bolt, 8mm x 20mm (196 cc)	4		8.704-654.0	Label, Logo Red (BXA Models)	1
50	8.919-423.0	Axle Holder Al Frame	2		8.900-870.0	Label, Logo Die-Cut (BGA Models)	1
51	9.802-810.0	Washer Flat 5/8"	2	81	8.901-219.0	Label, ETL, Mty, UL 1776	1
52	8.919-350.0	Al Back Beltguard Long (389 cc)	1	82	9.800-034.0	Label, Clear Lexan 4.3" X 5.5"	1
	8.919-402.0	Al Back Beltguard Short(196 cc)	1	83	8.750-284.0	Label Name Plate (HD Models)	1
53	8.919-351.0	Front Beltguard Long (389 cc)	1		8.750-285.0	Label NamePlate (PGA Models)	1
	8.919-403.0	Front Beltguard Short (196 cc)	1		8.750-286.0	Label Name Plate (BXA Models)	1
54	9.802-071.0	Al Trim, 750 B2 X 1/16	4.5 ft.		8.750-714.0	Label Name Plate (BGA Models)	1
55	8.919-796.0	Hose Hanger Al Frames	1	84	9.196-021.0	Socket Head Screw, 5/16"-24 x1.25" (196 cc)	1
56	9.802-809.0	Washer, 1/2" Flat	3	85	9.802-713.0	Bolt, 5/16" X 1-1/2" (196 cc)	1
57	9.803-551.0	Screw, 5/16" x 3/4"	3	86	9.198-014.0	Washer 21/64 X 1" (196 cc)	1
58	9.802-778.0	Nut, Whiz Loc 5/16 Flange	3	87	8.919-425.0	Al Muffler Deflector (196 cc)	1
59	8.932-993.0	Cushion, Pump	2			▲ Not Shown	
60	9.802-819.0	Washer, 7/16" x 2 1/2"	2				
61	9.802-958.0	Key, 0.185 SQR X 1.75" (196 cc)	1				
	9.802-959.0	Key, 0.247 SQR X 2.125" (389 cc)	1				
62	8.718-779.0	Scew, 4mm X 6 mm (196 cc)	2				
63	8.919-592.0	Suspension Bracket	2				
64	9.802-817.0	Washer, 3/8" x 1" (389 cc)	13				
65	9.802-053.0	Bushing, Fuel Line, Rubber	1				
66	8.736-004.0	Rubber Washer	1				
67	8.719-091.0	Spring, Foot, Compression	2				
68	8.706-557.0	Bellows, Leg (BOOT)	2				
69	8.719-954.0	Tube, PC Foot Bolt	2				
70	9.802-166.0	Coupler, 3/8" Socket, Female, Brass	1				
71	9.800-006.0	Label, Hot/Caliente W/Arrows	1				
72	8.917-015.0	Label, Regulation 4442.6	1				
73	8.901-137.0	Label, Beltguard Warning	1				
74	8.930-124.0	Label, Intended For Outdoor Use-Mexico	1				
75	8.783-034.0	Label, Quick Start Guide	1				

# D3030R.1 PUMP ASSEMBLY EXPLODED VIEW

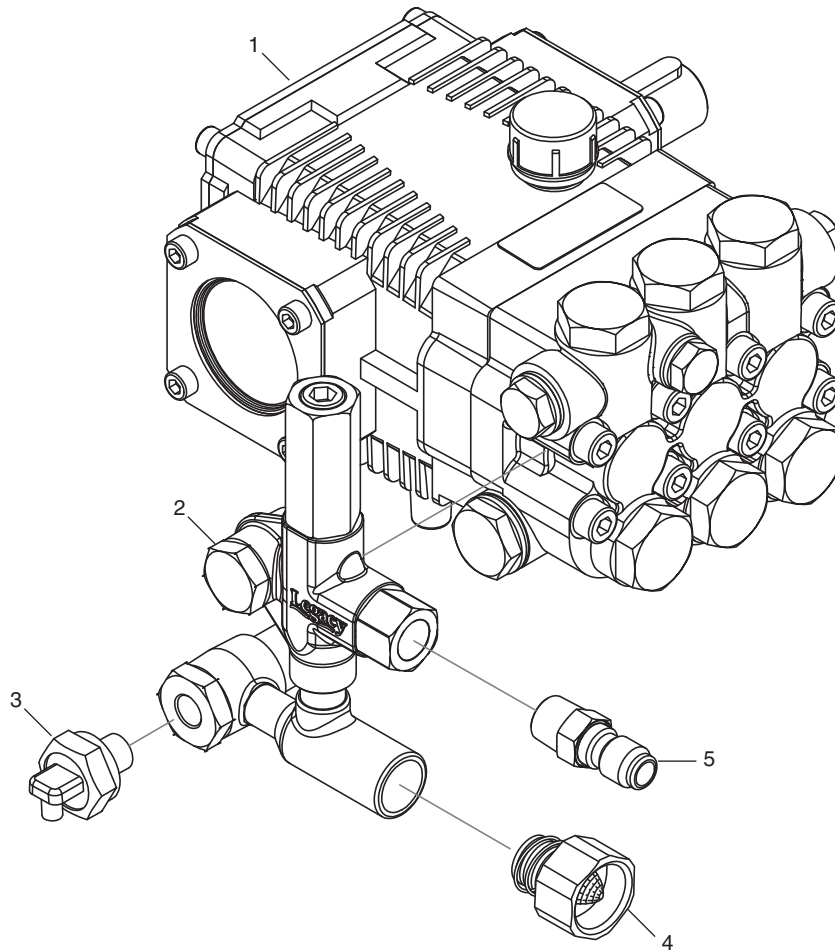

ITEM	PART NO.	DESCRIPTION	QTY
1	9.804-006.0	Pump, KD3030R.1, 3@3000,1650 RPM	1
	8.904-857.0	Pump, LD3030R.1, 3@3000, 1650 RPM	1
	8.904-730.0	Pump, HD3030R.1, 3@3000, 1650 RPM	1
2	9.175-018.0	UU1 3500PSI, Universal Unloader (SPARE)	1
3	9.804-025.0	Pump Protector, 1/4" 145 Deg	1
4	9.802-146.0	Swivel, 1/2" MP x 3/4" GHF W/Strainer	1
5	9.802-171.0	Coupler, 3/8" Plug, Male	1

## D.1 PUMP EXPLODED VIEW

8.725-169.0 LD 3025R.1  
 8.904-857.0 LD 3030R.1  
 8.904-856.0 LD 4020R.1

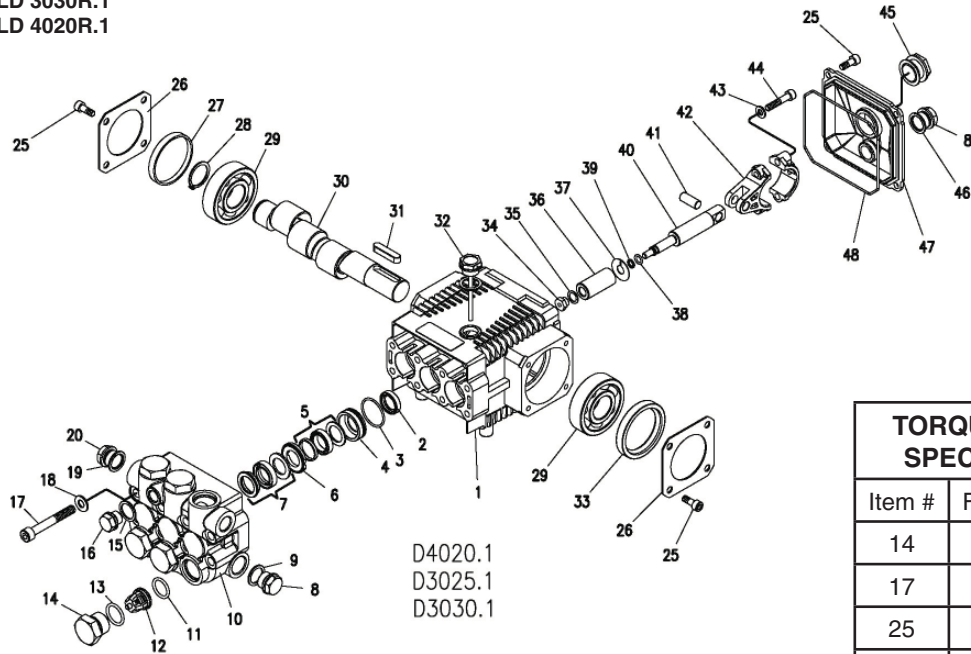

D4020.1  
 D3025.1  
 D3030.1

TORQUE SPECS	
Item #	Ft.-lbs
14	65
17	18
25	7.6
34	7
44	13

## LD.1 PUMP EXPLODED VIEW PARTS LIST

ITEM	PART NO.	DESCRIPTION	QTY	ITEM	PART NO.	DESCRIPTION	QTY
1	9.803-938.0	Crankcase	1	11*	9.803-947.0	O-Ring Ø1.78 x 15.54	6
2*	See Kits Below	Plunger Oil Seal	3	12*	See Kits Below	Valve Assembly	6
3*	See Kits Below	O-Ring Ø1.78 x 28.30	3	13*	9.803-948.0	O-Ring Ø2.62 x 18.77	6
4*	See Kits Below	Pressure Ring 15mm (3030)	3	14	9.803-949.0	Valve Plug	6
	See Kits Below	Pressure Ring 18mm (4020, 3025)	3	15	9.803-950.0	Copper Washer 1/4	1
5*	See Kits Below	U-Seal, 15mm (3030)	3	16	9.803-951.0	Brass Plug G1/4	1
	See Kits Below	U-Seal, 18mm (4020, 3025)	3	17	9.803-952.0	Manifold Stud Bolt	8
6*	See Kits Below	Intermediate Ring 15mm (3030)	3	18	9.802-884.0	Washer	8
	See Kits Below	Intermediate 18mm (4020, 3025)	3	19	9.803-198.0	Copper Washer 3/8	1
7*	See Kits Below	Intermed. Ring 15mm (3030)	3	20	9.802-925.0	Brass Plug 3/8	2
	See Kits Below	Intermed. Ring 18mm (4020, 3025)	3	25	9.802-939.0	Screw	12
8	9.802-926.0	Brass Plug 1/2"	1	26	9.803-953.0	Bearing Cover	2
9	9.803-199.0	Copper Washer 1/2"	1	27	9.803-954.0	Bearing Seal	1
10	9.803-946.0	Manifold Housing	1	28	9.802-914.0	Snap Ring	1
				29	9.803-955.0	Ball Bearing	2
				30	9.803-956.0	Crankshaft	1
				31	9.803-167.0	Crankshaft Key	1
				32	9.803-957.0	Oil Dipstick	1

## LD.1 PUMP EXPLODED VIEW PARTS LIST

ITEM	PART NO.	DESCRIPTION	QTY
33	8.933-010.0	Crankshaft Seal	1
34*	See Kits Below	Plunger Nut	3
35*	See Kit Below	Copper Spacer	3
36*	See Kits Below	Plunger, 15mm (3030)	3
	See Kits Below	Plunger, 18mm (4020, 3025)	3
37*	See Kits Below	Copper Spacer	3
38*	See Kits Below	O-Ring Ø1.78 x 5.28	3
39*	See Kits Below	Teflon Ring	3
40*	See Kits Below	Plunger Rod	3
41	9.803-965.0	Connecting Rod Pin	3
42	9.803-966.0	Connecting Rod	3
43	9.803-218.0	Spring Washer	6
44	8.933-020.0	Connecting Rod Screw	6
45	9.803-202.0	Sight Glass	1
46	9.803-197.0	Gasket	1
47	9.803-968.0	Crankcase Cover	1
48	9.803-969.0	O-Ring Ø2.62 x 107.62	

\* Available in kit (See below)

REPAIR KIT NUMBER	8.725-354.0	8.725-356.0	8.725-355.0	8.725-357.0	9.803-934.0	9.803-935.0	9.803-936.0	9.803-937.0
Kit Description	Plunger Seal 15mm D-3030	Plunger Seal 18mm D-3025 D-4020	Complete Seal Packing, 15mm D-3030	Complete Seal Packing, 18mm D-3025 D-4020	Plunger 15mm D-3030	Plunger 18mm D-3025 D4020	Complete Valve	Plunger Oil Seals
ITEM NUMBERS INCLUDED	3, 5, 7	3, 5, 7	3, 4, 5, 6, 7	3, 4, 5, 6, 7,	34, 35, 36, 37, 38	34, 35, 36, 37, 38	11, 12, 13	2
NUMBER OF CYLINDERS KIT WILL SERVICE	3	3	1	1	1	1	6	3

## UU1 UNLOADER EXPLODED VIEW

9.175-018.0

UU1 3500PSI, UNIVERSAL UNLOADER (SPARE)

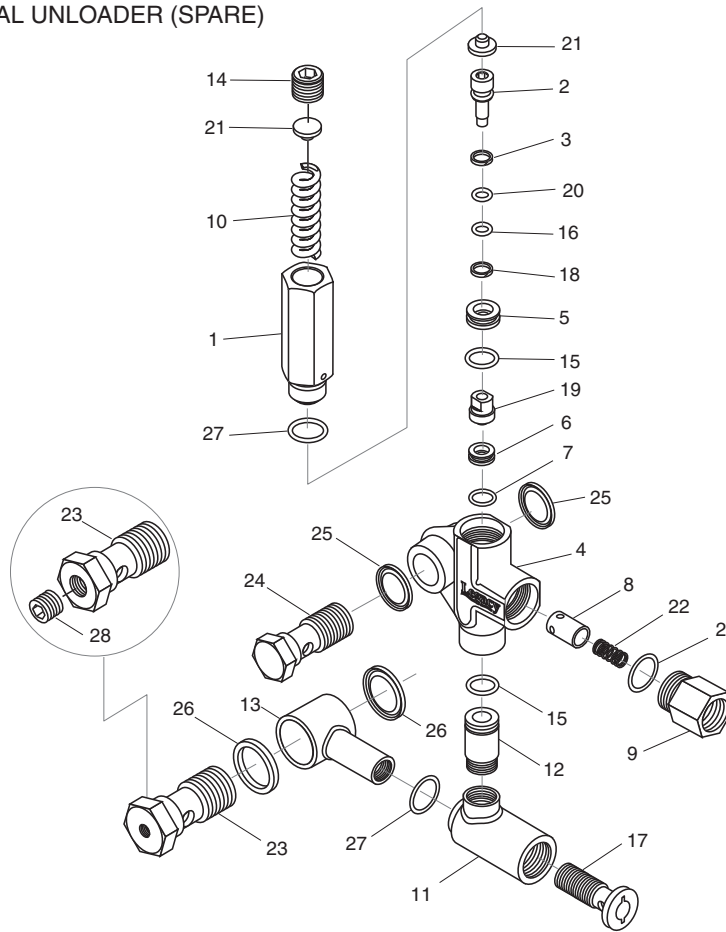

### UU1 UNLOADER EXPLODED VIEW PARTS LIST

ITEM	PART #	DESCRIPTION	KIT	QTY	ITEM	PART #	DESCRIPTION	KIT	QTY
1	8.751-394.0	Piston Housing	D	1	17	9.149-006.0	Sliding Connector Guide		1
2		Piston	C, D	1	18		O-Ring Backup 6 x 1.45 x 1.68	A, D	1
3		Piston O-Ring Back Up	A, D	1	19		Ball Housing Assy	C, D	1
4	8.749-796.0	Main Block		1	20		O-Ring 6.75 x 1.78 BN80	A, D	1
5	9.152-372.0	Piston Ring	D	1	21		Spring Seat	C, D	2
6		Ball Seat	C, D	1	22		Plunger Spring	B	1
7		O-Ring 10.5 ID x 1.5 CS	A,C,D	1	23	8.917-699.0	Banjo Bolt 1/2" Short		1
8		Plunger	B	1		8.917-700.0	Banjo Bolt 1/2"-1/4" NPT Short		1
9	9.152-016.0	Plunger Housing		1	24	8.917-698.0	Banjo Bolt 3/8" Short		1
10		Bypass Spring	C, D	1	25	9.802-893.0	Seal Washer 3/8"		2
11	9.149-001.0	Low Pressure Port		1	26	9.803-921.0	Seal Washer 1/2"		2
12	9.152-017.0	Sliding Connector, 30mm		1		9.802-893.0	Seal Washer 3/8"		2
	8.762-005.0	Sliding Connector, 40mm, Long		1	27		O-Ring 15 ID x 2CS	A,B,D	3
13	9.149-002.0	Sliding Connector H 1/2"		1	28	8.706-865.0	Plug, 1/4" Countersunk		1
	9.149-005.0	Sliding Connector H 3/8"		1	<b>Kit A</b>	9.104-038.0	O-Ring Repair Kit		
14	9.196-011.0	Plug 5/8 -18 UNF	D	1	<b>Kit B</b>	9.104-039.0	Outlet Kit		
15		O-Ring 12 ID x 2 CS	A, D	2	<b>Kit C</b>	9.104-040.0	Stem Basic Kit		
16		O-Ring 6 ID X 2 CS	A, D	1	<b>Kit D</b>	8.920-045.0	UU1 Complete Stem Kit		